



TECHNICAL DATA

MODEL V-BB SPECIFIC APPLICATION ATTIC SPRINKLER

The Viking Corporation, 210 N Industrial Park Drive, Hastings MI 49058

Telephone: 269-945-9501 Technical Services: 877-384-5464 Fax: 269-818-1680 Email: techsvcs@vikingcorp.com

1. DESCRIPTION

The Model V-BB (Back to Back) is a Specific Application Attic Sprinkler designed to provide superior fire protection in combustible and non-combustible sloped attic spaces when compared to standard spray attic protection. With specific application criteria for use with Model V-SD (Single Directional) and VK696 Attic Upright Specific Application Sprinklers, Viking attic sprinklers provide an extended coverage spacing alternative to standard spray sprinklers. They make it possible to use a single line of piping at the attic peak, eliminating the need for branch lines and greatly reducing the number of required sprinklers and associated material and installation costs. Model V-BB sprinklers also have lower minimum flow and pressure requirements than competitive products.

Viking Attic Sprinklers can be installed with either steel or CPVC piping (CPVC allowed on wet pipe systems only), and are available in brass or with corrosion-resistant Electroless Nickel PTFE (ENT) coatings where salt water and other corrosive elements are a consideration. They are cULus Listed with specific application guidelines for use as special sprinklers as defined by the National Fire Protection Association (NFPA), and are cULus Listed for extended coverage in combustible and non-combustible construction. The cULus Listing was achieved using full-scale fire tests within wood truss construction.

The Model V-BB Attic Sprinkler provides a reduced response time due to its narrow ridge spacing of 6 ft. (1,8 m) and long throw pattern (up to 30 ft. in each direction measured horizontally), and is offered in three different slope ranges and two different orifice sizes (K=5.6 or 8.0). Listed for specific pitches 4:12<7:12, 7:12<10:12, and 10:12≤12:12; and spans of 60 ft. and 40 ft. The 8.0K can protect up to 80 ft. span when used along with the Model Attic Upright VK696.

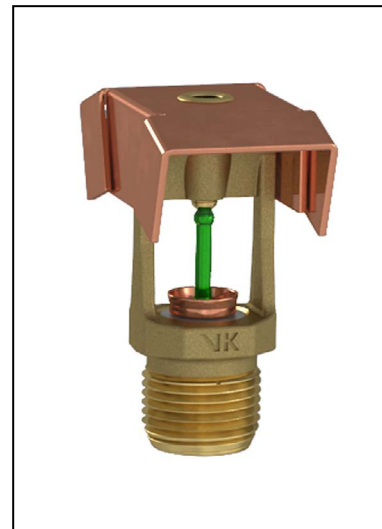

V-BB Sprinkler

8.0K	5.6K	Pitch
VK681	VK684	4:12 < 7:12
VK682	VK685	7:12 < 10:12
VK683	VK686	10:12 ≤ 12:12

2. LISTINGS AND APPROVALS

 cULus Listed: Category VNIV
Refer to the Approval Chart on page 4.

3. TECHNICAL DATA

Specifications:

Minimum Operating Pressure: See Design Criteria - UL
Rated to 175 psi (12 bar) water working pressure
Factory tested hydrostatically to 500 psi (34.5 bar)
Thread size: 1/2" (15 mm) or 3/4" (19 mm) NPT
Nominal K-Factor: 5.6 U.S. (80.6 metric*) or 8.0 (115.2 metric*)

* Metric K-factor measurement shown is when pressure is measured in Bar. When pressure is measured in kPa, divide the metric K-factor shown by 10.0.

Glass-bulb fluid temperature rated to -65 °F (-55 °C)
Overall Length: 2-5/8" (67,6 mm)
Covered by the following US Patent No.: 9,149,818

Material Standards:

Frame Casting: Brass UNS-C84400 or QM Brass
Deflector: Brass UNS-C23000
Bulb: Glass, nominal 3 mm diameter
Belleville Spring Sealing Assembly: Nickel Alloy, coated on both sides with Teflon Tape
Screw: Brass UNS-C36000
Pip Cap and Insert Assembly: Copper UNS-C11000 and Stainless Steel UNS-S30400

Ordering Information: (Also refer to the current Viking price list.)

To order the Attic Sprinkler, add the appropriate suffix for the sprinkler finish and then the appropriate suffix for the temperature rating to the sprinkler base part number.

Finish Suffix: Brass = A, ENT = JN
Temperature Suffix: E = 200 °F (93.3 °C)

Viking Technical Data may be found on
The Viking Corporation's Web site at
<http://www.vikinggroupinc.com>.
The Web site may include a more recent
edition of this Technical Data Page.



TECHNICAL DATA

MODEL V-BB SPECIFIC APPLICATION ATTIC SPRINKLER

The Viking Corporation, 210 N Industrial Park Drive, Hastings MI 49058

Telephone: 269-945-9501 Technical Services: 877-384-5464 Fax: 269-818-1680 Email: techsvcs@vikingcorp.com

Available Finishes And Temperature Ratings:

Refer to the approval chart on page 4.

Accessories: (Also refer to the "Sprinkler Accessories" section of the Viking website under Technical Data)

Sprinkler Wrench:

Standard Wrench: Part No. 10896W/B

Sprinkler Cabinets:

A. Six-head capacity: Part No. 01724A

B. Twelve-head capacity: Part No. 01725A

4. INSTALLATION

Refer to appropriate NFPA Installation Standards.

5. OPERATION

During a fire condition, the heat sensitive liquid in the glass bulb expands, causing the glass to shatter, releasing the pip cap and sealing spring assembly. Water flowing through the sprinkler orifice strikes the deflector, forming a uniform spray pattern to extinguish or control the fire, and protect the piping in the interstitial space.

6. INSPECTIONS, TESTS AND MAINTENANCE

Refer to NFPA 25 for Inspection, Testing and Maintenance requirements.

7. AVAILABILITY

The Model V-BB Specific Application Sprinkler is available through a network of domestic and international distributors. See The Viking Corporation web site for the closest distributor or contact The Viking Corporation.

8. GUARANTEE

For details of warranty, refer to Viking's current list price schedule or contact Viking directly.

TABLE 1: AVAILABLE SPRINKLER TEMPERATURE RATINGS AND FINISHES

Sprinkler Temperature Classification	Sprinkler Nominal Temperature Rating ¹	Maximum Ambient Ceiling Temperature ²	Bulb Color
Intermediate	200 °F (93.3 °C)	150 °F (65°C)	Green

Sprinkler Finishes: Brass, ENT³

Footnotes

¹ The sprinkler temperature rating is stamped on the deflector.

² Based on NFPA-13. Other limits may apply, depending on fire loading, sprinkler location, and other requirements of the Authority Having Jurisdiction. Refer to specific installation standards.

³ cULus Listed as corrosion resistant.



TECHNICAL DATA

**MODEL V-BB
SPECIFIC APPLICATION
ATTIC SPRINKLER**

The Viking Corporation, 210 N Industrial Park Drive, Hastings MI 49058
 Telephone: 269-945-9501 Technical Services: 877-384-5464 Fax: 269-818-1680 Email: techsvcs@vikingcorp.com

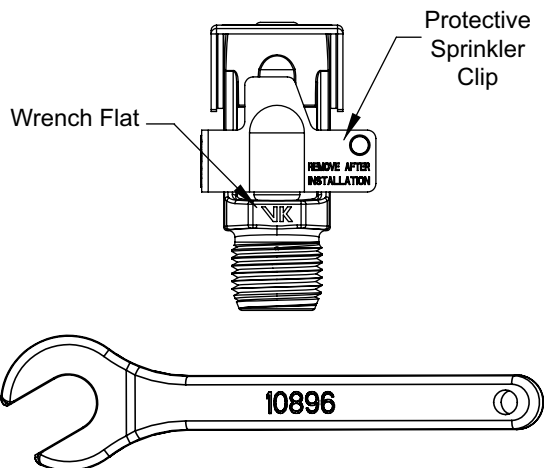

**Figure 1:
Standard Sprinkler Wrench 10896W/B**

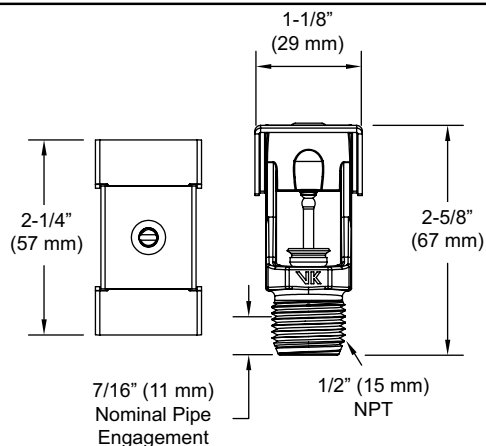

**Figure 2a:
Sprinkler Dimensions - 5.6K**

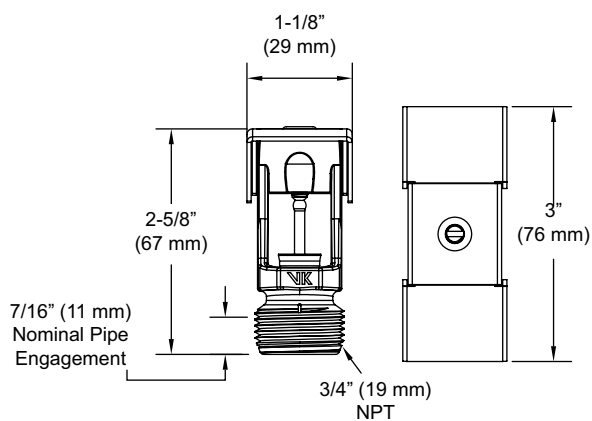

**Figure 2b:
Sprinkler Dimensions - 8.0K**



TECHNICAL DATA

MODEL V-BB SPECIFIC APPLICATION ATTIC SPRINKLER

The Viking Corporation, 210 N Industrial Park Drive, Hastings MI 49058
 Telephone: 269-945-9501 Technical Services: 877-384-5464 Fax: 269-818-1680 Email: techsvcs@vikingcorp.com

Approval Chart 1

Viking V-BB Specific Application Sprinkler
 For Combustible and Non-Combustible Sloped Attic Spaces

KEY	
Temperature	→
Finish	↓
A1X ←	Escutcheon (if applicable)

Part Number ¹	SIN	Maximum Pressure	Thread Size		Nominal K-Factor		Overall Length		Listings and Approvals ³				
			NPT	BSP	U.S.	metric ²	Inches	mm	cULus ⁴	FM	LPCB	CE	⚙
19627	VK684	175 psi	1/2"	15 mm	5.6	80,6	2-5/8	68	A1, A2	--	--	--	--
19801	VK685	175 psi	1/2"	15 mm	5.6	80,6	2-5/8	68	A1, A2	--	--	--	--
19754	VK686	175 psi	1/2"	15 mm	5.6	80,6	2-5/8	68	A1, A2	--	--	--	--
19626	VK681	175 psi	3/4"	20 mm	8.0	115,2	2-5/8	68	A1, A2	--	--	--	--
19798	VK682	175 psi	3/4"	20 mm	8.0	115,2	2-5/8	68	A1, A2	--	--	--	--
19751	VK683	175 psi	3/4"	20 mm	8.0	115,2	2-5/8	68	A1, A2	--	--	--	--
Approved Temperature Rating							Approved Finishes						
A - 200 °F (93.3 °C)							1 - Brass, 2 - ENT ⁵						

¹ Also refer to Viking's current price schedule.

² Metric K-factor measurement shown is when pressure is measured in Bar. When pressure is measured in kPa, divide the metric K-factor shown by 10.0.

³ This table shows the listings and approvals available at the time of printing. Other approvals may be in process.

⁴ Listed by Underwriters Laboratories Inc for use in the United States and Canada.

⁵ cULus Listed as corrosion resistant.

DESIGN CRITERIA - UL Chart 1

(Also refer to Approval Chart 1)
 Allowable , flow, pressure and slope for attic protection using Viking V-BB Sprinklers

Sprinkler Base Part Number	SIN	Type	Thread Size		Nominal K-Factor		Allowable Roof Span ² ft. (m)	Minimum Flow		Minimum Pressure		Pitch ¹	Dry Pipe System Maximum Water Delivery Time ³ (in seconds)
			NPT	BSP	U.S.	metric		GPM	LPM	PSI	BAR		
19627	VK684	V-BB	1/2"	15 mm	5.6	80,6	≤40 (12,2)	24	91	18.4	1,3	4:12 < 7:12	See footnote 3
19801	VK685	V-BB	1/2"	15 mm	5.6	80,6	≤40 (12,2)	24	91	18.4	1,3	7:12 < 10:12	See footnote 3
19754	VK686	V-BB	1/2"	15 mm	5.6	80,6	≤40 (12,2)	24	91	18.4	1,3	10:12 ≤ 12:12	See footnote 3
19626	VK681	V-BB	3/4"	20 mm	8.0	115,2	≤60 (18,3)	38	144	22.6	1,5	4:12 < 7:12	See footnote 3
19798	VK682	V-BB	3/4"	20 mm	8.0	115,2	≤60 (18,3)	38	144	22.6	1,5	7:12 < 10:12	See footnote 3
19751	VK683	V-BB	3/4"	20 mm	8.0	115,2	≤60 (18,3)	38	144	22.6	1,5	10:12 ≤12:12	See footnote 3

¹ Pitch and slope indicate the incline of a roof, expressed as a proportion of the vertical to the horizontal.

² Refer to the Viking Attic Upright VK696 data sheet for roof spans over 60 ft (18,29 m) up to 80 ft (24,38 m) wide.

³ Refer to NFPA 13, 2013, Section 7.2.3.

IMPORTANT: Always refer to Bulletin Form No. F_091699 - Care and Handling of Sprinklers. Also refer to page SR1-3 for general care, installation, and maintenance information. Viking sprinklers are to be installed in accordance with the latest edition of Viking technical data, the appropriate standards of NFPA, LPCB, APSAD, VdS or other similar organizations, and also with the provisions of governmental codes, ordinances, and standards, whenever applicable.



TECHNICAL DATA

MODEL V-BB SPECIFIC APPLICATION ATTIC SPRINKLER

The Viking Corporation, 210 N Industrial Park Drive, Hastings MI 49058

Telephone: 269-945-9501 Technical Services: 877-384-5464 Fax: 269-818-1680 Email: techsvcs@vikingcorp.com

ADDITIONAL DESIGN CRITERIA - UL Chart 2

(Also refer to DESIGN CRITERIA Chart 1)

Allowable roof span, flow, pressure and slope for attic protection using Viking V-BB Sprinklers

Design Criteria: Flow and Pressures refer to Design Chart 1.

System Type:

Wet systems and dry systems.

Piping Types:

Steel (wet and dry) CPVC (wet systems only).

Occupancy Classification: Light hazard only.

Viking V-BB Sprinkler Spacing

Maximum Coverage Area:

400 ft² (37,16 m²) as measured along the slope.

Coverage area is determined by the twice the maximum distance thrown measured along the slope, multiplied by the distance along the branch line.

Example: 60' (18,3 m) span with a 10:12 slope, when measured along the slope provides a distance of approximately 39'-1" (11,9 m). This number must be multiplied by 2 to equal the overall span, which would be approximately 78'-2" (23,8 m).

400 ft² divided by 78'-2" (23,8 m) allows a maximum spacing along the branchline of 5'-1" (15,5 m).

Along the Branch Line:

Minimum Spacing: 4'-0" (1,2 m) between V-BB's and from V-SD's. 7'-0" (2,1 m) from Viking Attic Uprights. 6'-0" (1,8 m) from Standard Spray Sprinklers

Maximum Spacing: 6'-0" (1,8 m) between V-BB's and from V-SD's.

Measured Down the Slope:

Minimum Spacing: 26'-0" (7,9 m) from Viking Attic Uprights and Standard Spray Sprinklers.

Deflector Position below Peak, Ridge, or Deck:

For all roof pitches as per the listing from 4:12 – 12:12 the maximum deflector distance down is 22" (560 mm), and the minimum deflector distance down is 16" (405 mm).

Deflector Position above Scissor Truss:

For all roof pitches as per the listing from 4:12 – 12:12 the minimum distance above a scissor truss is 18" (458 mm).

Maximum distance from center line of the ridge:

6" (152 mm) on either side of the center line.

Minimum distance from Truss:

6" (152 mm) from nearest edge of the truss.

Draft Curtains:

Where used to allow Attic Upright Sprinkler installation shall be constructed to contain heat, may be constructed of minimum ½" (13 mm) plywood or equivalent.

Continues on next page.



TECHNICAL DATA

MODEL V-BB SPECIFIC APPLICATION ATTIC SPRINKLER

The Viking Corporation, 210 N Industrial Park Drive, Hastings MI 49058

Telephone: 269-945-9501 Technical Services: 877-384-5464 Fax: 269-818-1680 Email: techsvcs@vikingcorp.com

Continued from previous page.

Use of UL Listed CPVC Blazemaster Piping (Wet Systems Only):

Can be used to supply the sprinklers protecting the floor below the combustible concealed space when covered with 6" (152 mm) of non-combustible insulation over the horizontal or vertical piping, and extending 12" (304 mm) on both sides of the center line of the piping. If the piping is located in the joist, the width of the joist channel must be entirely covered to 6" (152 mm) above the top of the piping. The area above the piping must be protected with the Model V-BB's, V-SD's, or the Attic Upright Sprinklers.

Listed CPVC Blazemaster piping may also be used exposed to feed wet systems using Viking V-BB sprinklers in accordance with the following requirements, and in accordance with Figure 15:

- Risers are vertical and protected by V-BB or V-SD sprinklers located a maximum of 12 (304 mm)" away from the riser centerline.
- Model V-BB or V-SD sprinklers are mounted directly to the branchline.
- Model V-BB or V-SD sprinklers are installed on arm-overs a maximum of 6" (152 mm) laterally from the center line of the branch line.
- Model V-BB or V-SD sprinklers are installed on Vertical Sprigs attached to the branchline.
- Model V-BB or V-SD sprinklers are installed on angled sprigs a maximum of 6" (152 mm) laterally from the centerline of the branchline.
- Installed with a minimum lateral distance of 18" (456 mm) from any device that produces and releases heat, i.e. attic furnace, kitchen or bathroom exhaust fan, flue vents, heat lamps, and other such devices.

NOTICE

Insulation requirements are provided solely for Fire Protection purposes and not for freeze protection.

NOTICE

Non-combustible insulation being used needs to be verified for chemical compatibility with the CPVC piping at www.lubrizol.com

Obstruction Criteria:

Refer to Figures 4—14

Refer to Sections 8.8.5.2.1.3 and 8.8.5.2.1.7 of NFPA 13, 2013 for requirements if installed on greater than 2-1/2" (64 mm) diameter piping.

Hydraulic Requirements:

Viking V-BB Sprinklers must be calculated in accordance with the following figures and guidelines.

The design area shall include the most hydraulically demanding sprinklers, and in certain cases may require more than one set of calculations to verify the system's design.

The following figures cover Hydraulic Requirements for Viking V-BB Sprinklers only, and when installed with Attic Upright or Standard Spray Sprinklers.

For areas using Viking V-SD Sprinklers refer to the applicable data sheets.

Refer to Figures-unless otherwise noted, all Figures portray a 60' (18,3 m) roof span:

Figure 16 – V-BB Sprinklers

Figure 17 – V-BB Sprinklers & Attic Upright or Standard Spray Sprinklers Beyond an Obstruction

Figure 18 – V-BB Sprinklers & Attic Upright or Standard Spray Sprinklers at the Hip

Figure 19 – V-BB Sprinklers & Attic Upright or Standard Spray Sprinklers in a Dormer, at a Hip, or at an Eil.

Figure 20 – V-BB Sprinklers & Attic Upright or Standard Spray Sprinklers separated by compartmentalization.

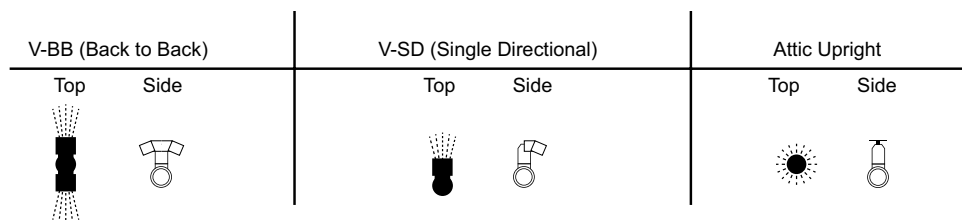

	TECHNICAL DATA	MODEL V-BB SPECIFIC APPLICATION ATTIC SPRINKLER
---	-----------------------	--

The Viking Corporation, 210 N Industrial Park Drive, Hastings MI 49058
 Telephone: 269-945-9501 Technical Services: 877-384-5464 Fax: 269-818-1680 Email: techsvcs@vikingcorp.com

Refer to figures 4 and 5 below-unless otherwise noted, all Figures portray a 60' (18,3 m) roof span. Maximum 6" (152 mm) obstruction allowed provided it sits at least 36" (914 mm) vertically below the Viking V-BB Sprinkler. Larger or closer obstructions require an additional sprinkler on the opposite side of the obstruction. This criteria only limits the obstructions that run across the trusses or rafters, not the top chord of the trusses or the depth of the rafter.

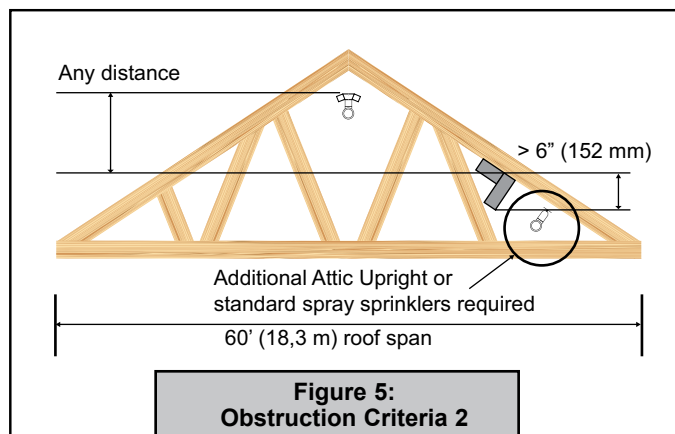
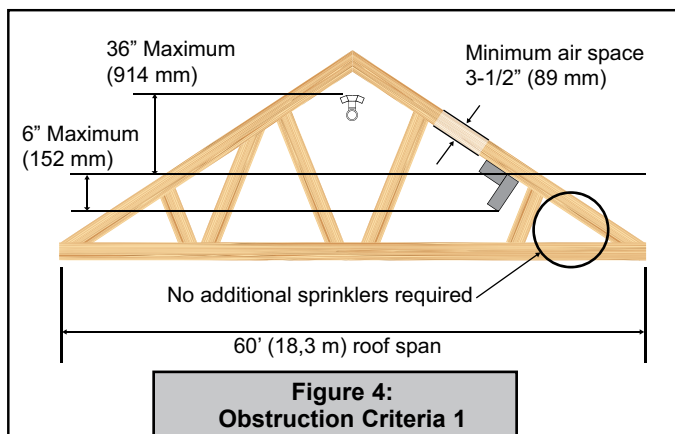

Refer to Figures 6 and 7 below where the maximum spacing for Attic Upright Sprinklers is 12 ft. (3,7 m) and standard spray sprinklers is 15 ft (4,6 m). Any horizontal obstruction that is 4 ft. (1,2 m) or less in width requires minimum 6" (152 mm) clearance over the top to allow for sufficient water flow over and under. The clearance must be measured perpendicular to and from the bottom of the rafter. If the clearance is less than 6" (152 mm), an additional sprinkler is required on the opposite side of the obstruction. If the obstruction is more than 4 ft. (1,2 m) wide, an additional sprinkler is required underneath.

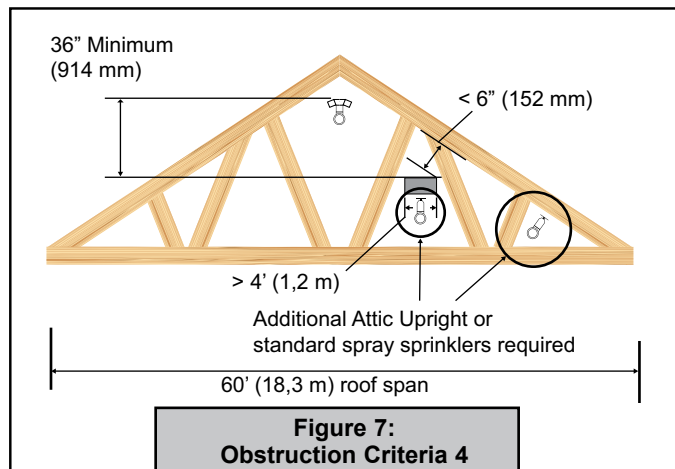
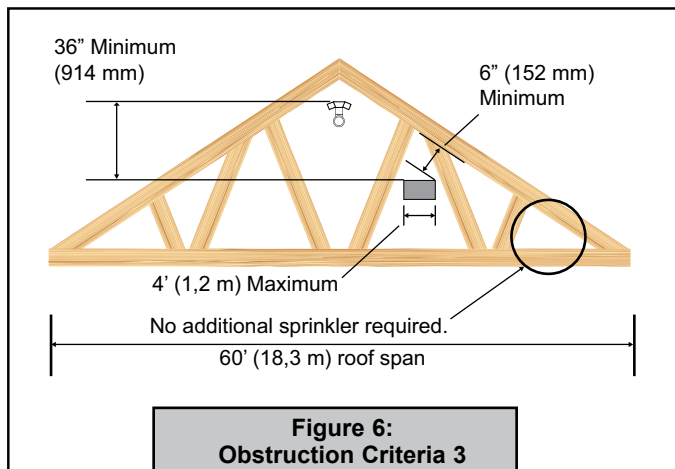

	TECHNICAL DATA	MODEL V-BB SPECIFIC APPLICATION ATTIC SPRINKLER
---	-----------------------	--

The Viking Corporation, 210 N Industrial Park Drive, Hastings MI 49058
Telephone: 269-945-9501 Technical Services: 877-384-5464 Fax: 269-818-1680 Email: techsvcs@vikingcorp.com

Refer to Figure 8 below. For vertical obstructions, the maximum dimension of the obstruction is the width and the horizontal distance is measured horizontally.

TABLE 2: OBSTRUCTION CRITERIA

Dimension X	Distance Y	Additional Sprinklers Required Beyond Obstruction
Maximum Horizontal Dimension of Obstruction	Minimum Horizontal Distance to Obstruction	
All vertical obstructions	< 6" (152 mm)	YES
1/2" - 1" (13 mm - 25 mm)	6" (152 mm)	NO
1" - 4" (25 mm - 102 mm)	12" (305 mm)	NO
4" - 8" (101 mm - 203 mm)	24" (610 mm)	NO
8" - 10" (203 mm - 254 mm)	5'-0" (1,5 m)	NO
10" - 20" (254 mm - 508 mm)	10'-0" (3,0 m)	NO
20" - 30" (508 mm - 762 mm)	15'-0" (4,6 m)	NO
30" - 40" (762 mm - 1016 mm)	20'-0" (6,1 m)	NO
40" - 48" (1016 mm - 1219 mm)	25'-0" (7,6 m)	NO
> 48" (1219 mm)	Any distance	YES

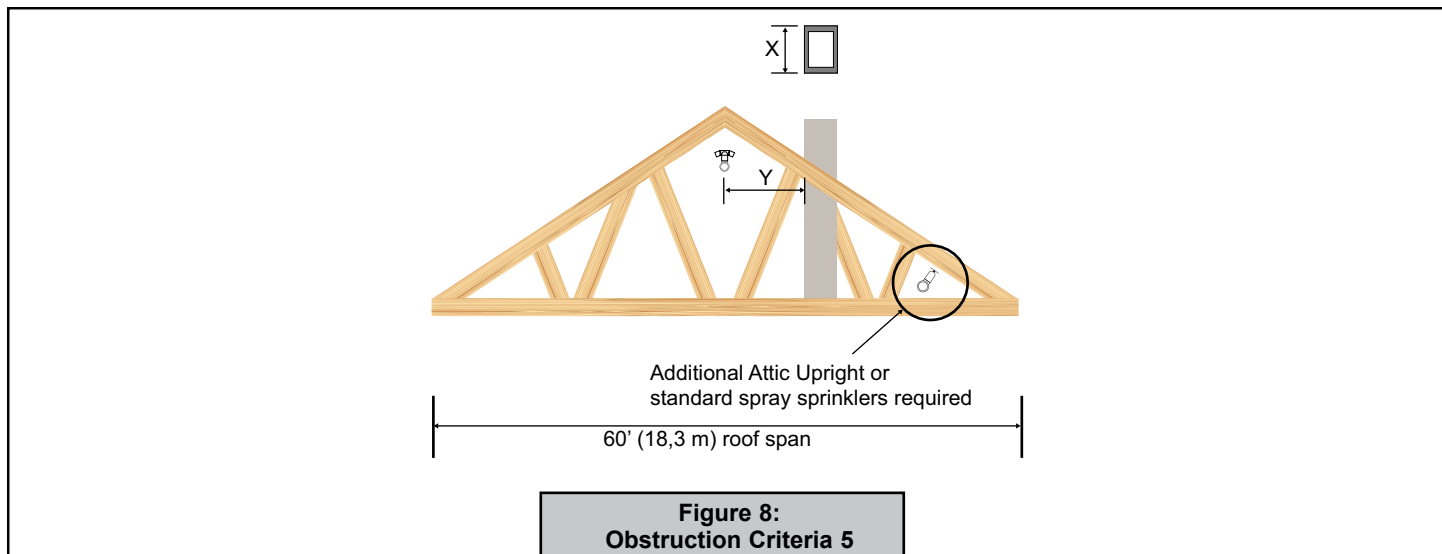

	TECHNICAL DATA	MODEL V-BB SPECIFIC APPLICATION ATTIC SPRINKLER
---	-----------------------	--

The Viking Corporation, 210 N Industrial Park Drive, Hastings MI 49058
Telephone: 269-945-9501 Technical Services: 877-384-5464 Fax: 269-818-1680 Email: techsvcs@vikingcorp.com

If a V-BB Sprinkler is 36" (914 mm) or greater above the space, and 36" (914 mm) or greater clearance above the space is present, additional sprinklers are not needed.

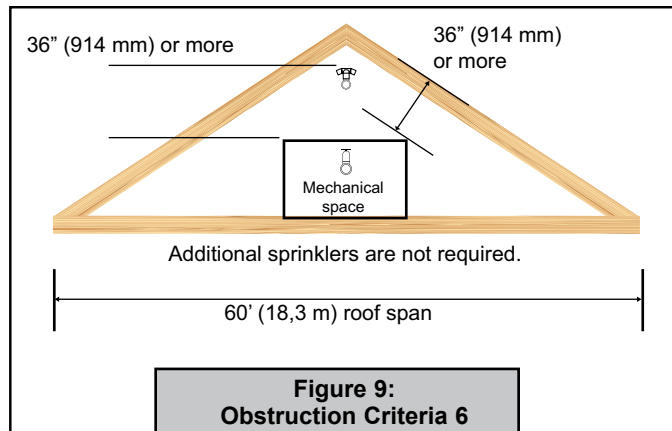

If a V-BB sprinkler is 36" (914 mm) or greater above the space, and a 12" - 36" (304 - 914 mm) clearance above the space is present, intermediate level standard sprinklers are required.

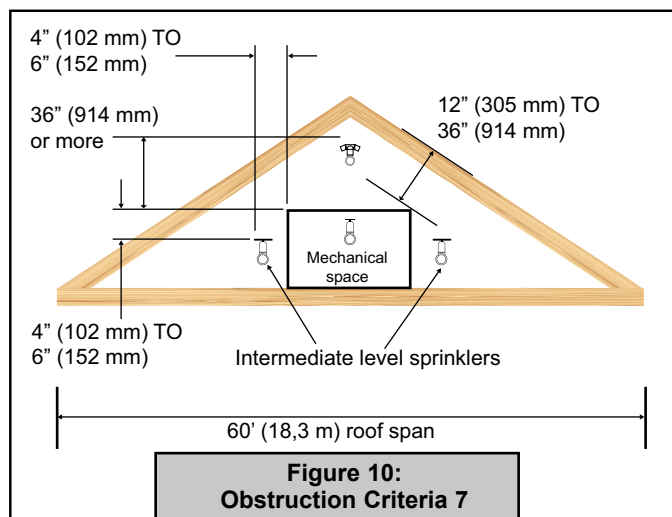

Otherwise, the area outside the mechanical space is to be protected as shown using standard spray sprinklers as necessary or by building a shear wall and installing V-SD Sprinklers.

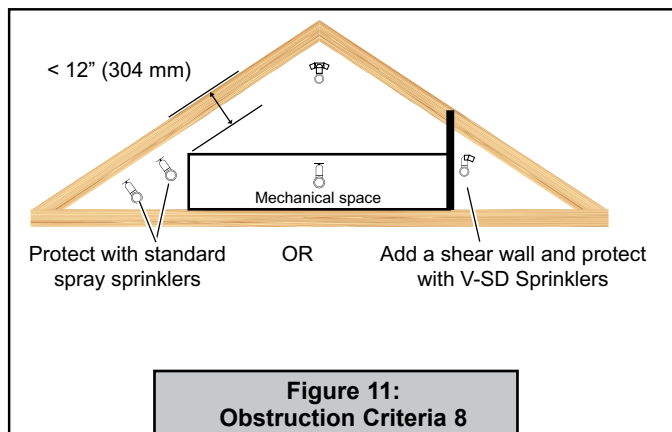

	TECHNICAL DATA	MODEL V-BB SPECIFIC APPLICATION ATTIC SPRINKLER
---	-----------------------	--

The Viking Corporation, 210 N Industrial Park Drive, Hastings MI 49058
Telephone: 269-945-9501 Technical Services: 877-384-5464 Fax: 269-818-1680 Email: techsvcs@vikingcorp.com

If a V-BB Sprinkler can be installed below or between stiffeners and 16 to 22" (404 to 559 mm) distance to peak can be maintained, as well as A and B clearances to the stiffeners, no additional sprinklers are required.

A	B		
	VK681 VK684	VK682 VK685	VK683 VK686
0"	0"	0"	0"
A > 0"	A + 15"	A + 10"	A + 8"

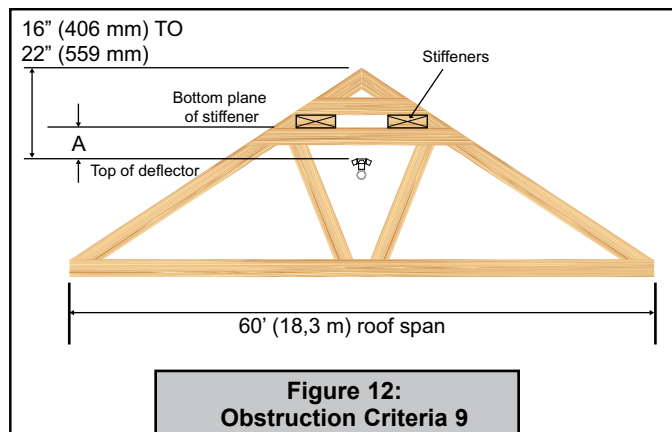
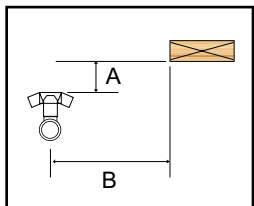

When the stiffeners are located a minimum of 12" (305 mm) below the V-BB Sprinkler, the stiffeners are 7-12" (190 mm) maximum wide, the openings are 12" (305 mm) minimum, and there is 70% minimum open area, no additional sprinklers are required.

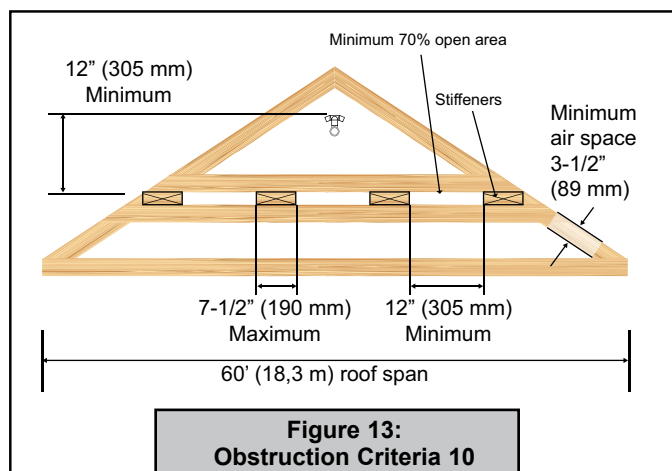

Otherwise, additional sprinklers are required as shown.

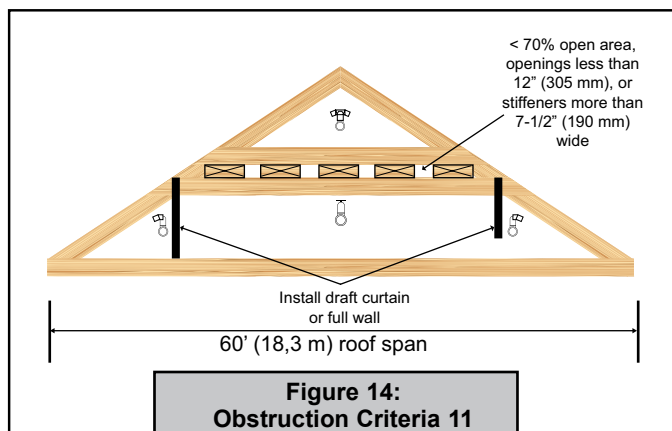



TECHNICAL DATA

MODEL V-BB
SPECIFIC APPLICATION
ATTIC SPRINKLER

The Viking Corporation, 210 N Industrial Park Drive, Hastings MI 49058
 Telephone: 269-945-9501 Technical Services: 877-384-5464 Fax: 269-818-1680 Email: techsvcs@vikingcorp.com

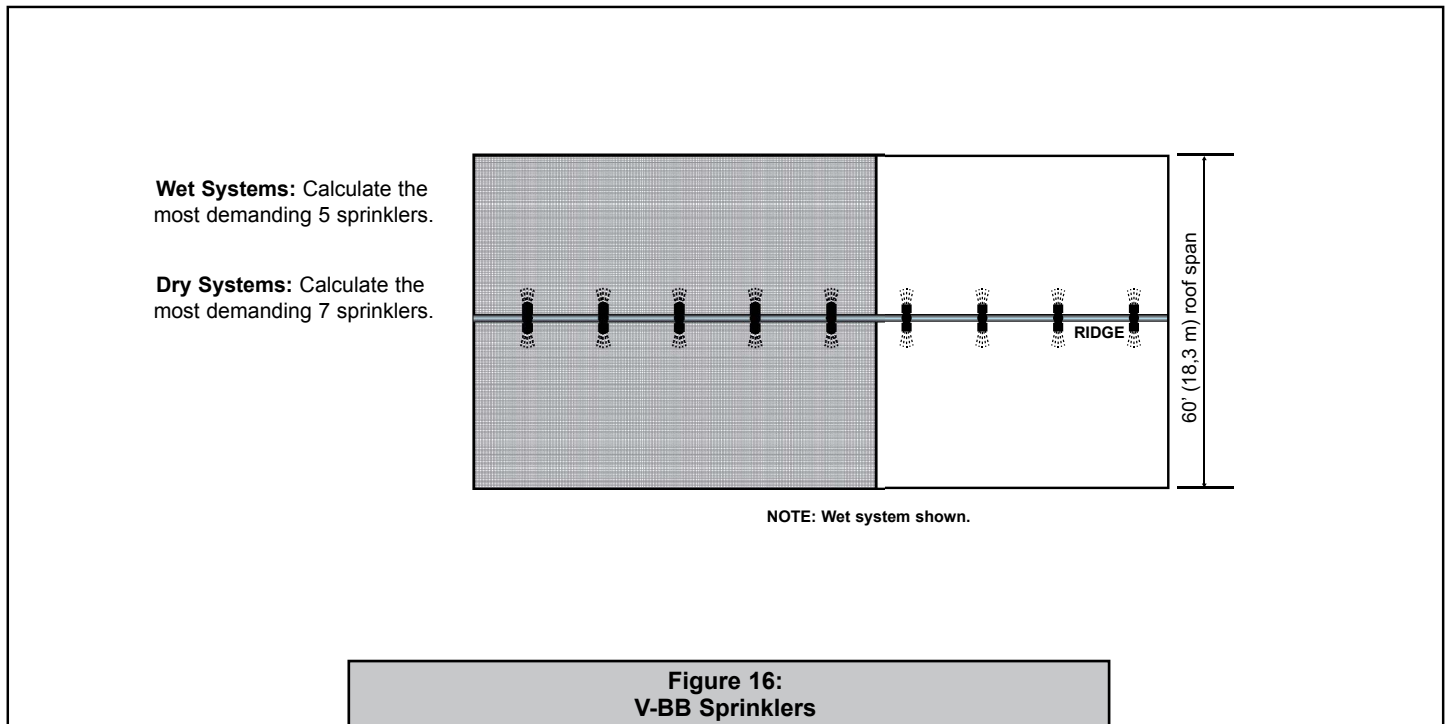
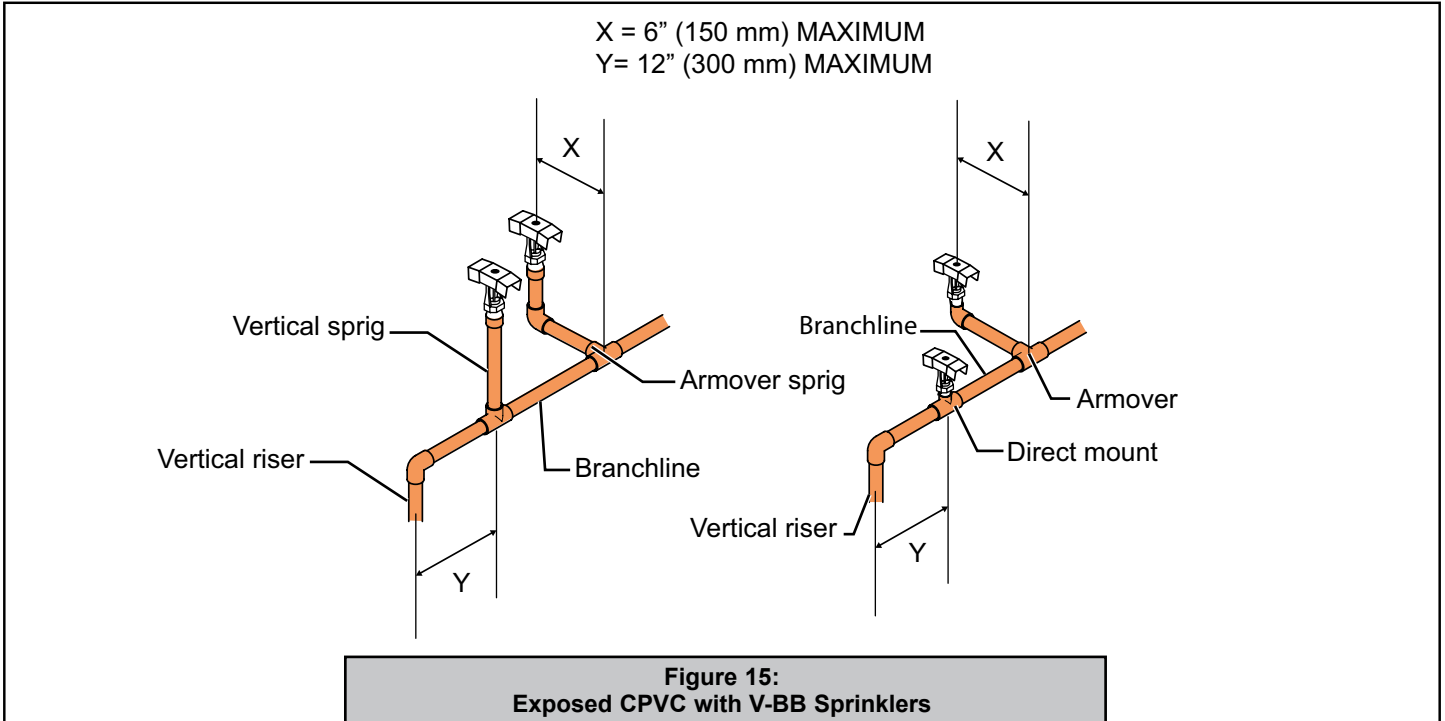



TECHNICAL DATA

MODEL V-BB
SPECIFIC APPLICATION
ATTIC SPRINKLER

The Viking Corporation, 210 N Industrial Park Drive, Hastings MI 49058
 Telephone: 269-945-9501 Technical Services: 877-384-5464 Fax: 269-818-1680 Email: techsvcs@vikingcorp.com

Wet Systems: Calculate the most demanding 5 V-BB sprinklers and add up to 2 of the most demanding Attic Upright or Standard Spray Sprinklers.

Dry Systems: Calculate the most demanding 7 V-BB sprinklers and add up to 2 of the most demanding Attic Upright or Standard Spray Sprinklers.

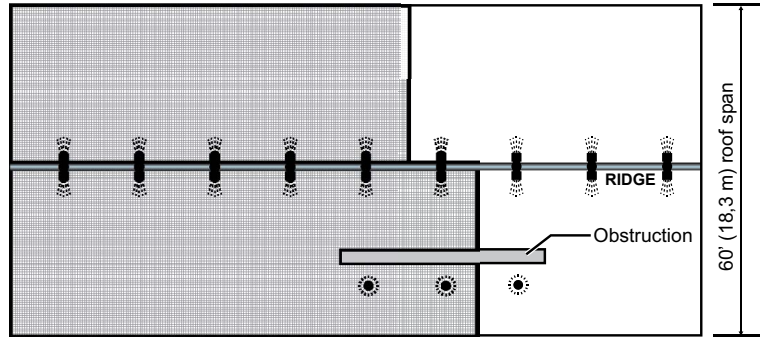

NOTE: Wet system shown.

Figure 17:
V-BB and Attic Upright or Standard Spray Sprinklers Beyond an Obstruction



TECHNICAL DATA

MODEL V-BB
SPECIFIC APPLICATION
ATTIC SPRINKLER

The Viking Corporation, 210 N Industrial Park Drive, Hastings MI 49058
 Telephone: 269-945-9501 Technical Services: 877-384-5464 Fax: 269-818-1680 Email: techsvcs@vikingcorp.com

Wet Systems: Calculate the most demanding 5 V-BB sprinklers plus the 2 most demanding Attic Upright Sprinklers, and then calculate the most demanding area up to 1500 ft² (137m²) having Attic Upright sprinklers. Use the most demanding calculation.

Wet Systems: Calculate the most demanding 5 V-BB Sprinklers and add up to 2 of the most demanding Standard Spray Sprinklers, then calculate the most demanding remote design area (including ALL sprinkler types) per NFPA 13. For example, area reduction for quick response and 30% increase for sloped ceilings. Use the most demanding calculation.

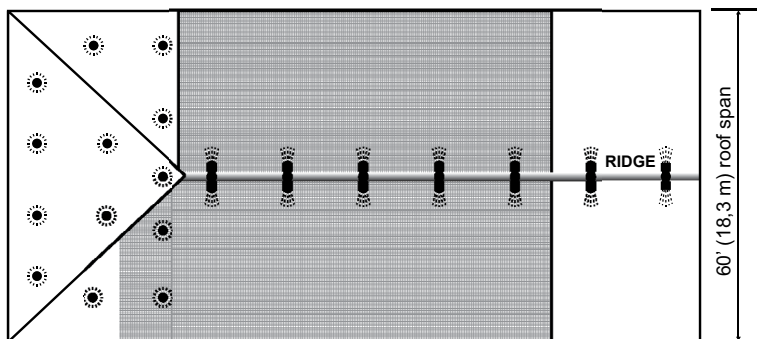

NOTE: Wet system shown.

Dry Systems: Calculate the most demanding 7 V-BB sprinklers plus the 2 most demanding Attic Upright sprinklers, and then calculate the most demanding area up to 1950 ft² (181 m²) having Attic Upright sprinklers. Use the most demanding calculation.

Dry Systems: Calculate the most demanding 7 V-BB Sprinklers and add up to 2 of the most demanding Standard Spray Sprinklers, then calculate the most demanding remote design area (including ALL sprinkler types) per NFPA 13. For example, 30% increase for sloped ceilings and 30% increase for dry systems. Use the most demanding calculation.

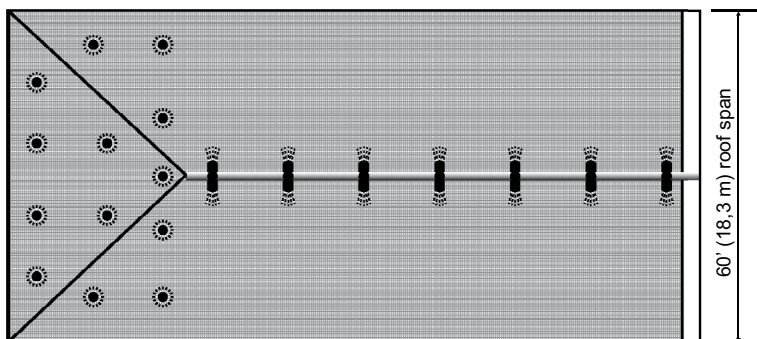

NOTE: Wet system shown.

Figure 18:
V-BB and Attic Upright or Standard Spray Sprinklers at the Hip



TECHNICAL DATA

MODEL V-BB
SPECIFIC APPLICATION
ATTIC SPRINKLER

The Viking Corporation, 210 N Industrial Park Drive, Hastings MI 49058

Telephone: 269-945-9501 Technical Services: 877-384-5464 Fax: 269-818-1680 Email: techsvcs@vikingcorp.com

Where the quantity of Attic Upright or Standard Spray sprinklers in each dormer, cross, or ell is 4 or less and all of the dormers, crosses and ells meet the maximum 4 standard sprinkler criteria, calculate the V-BB demand as shown in Figures 16 and 17, and add up to 2 of the most demanding Attic Upright or Standard Spray sprinklers in the dormer, cross, or ell that is adjacent to the Attic Upright Sprinklers that are being included in the demand calculation.

Where the quantity of Attic Upright or Standard Spray sprinklers in any dormer, cross, or ell is greater than four, refer to Figure 18.

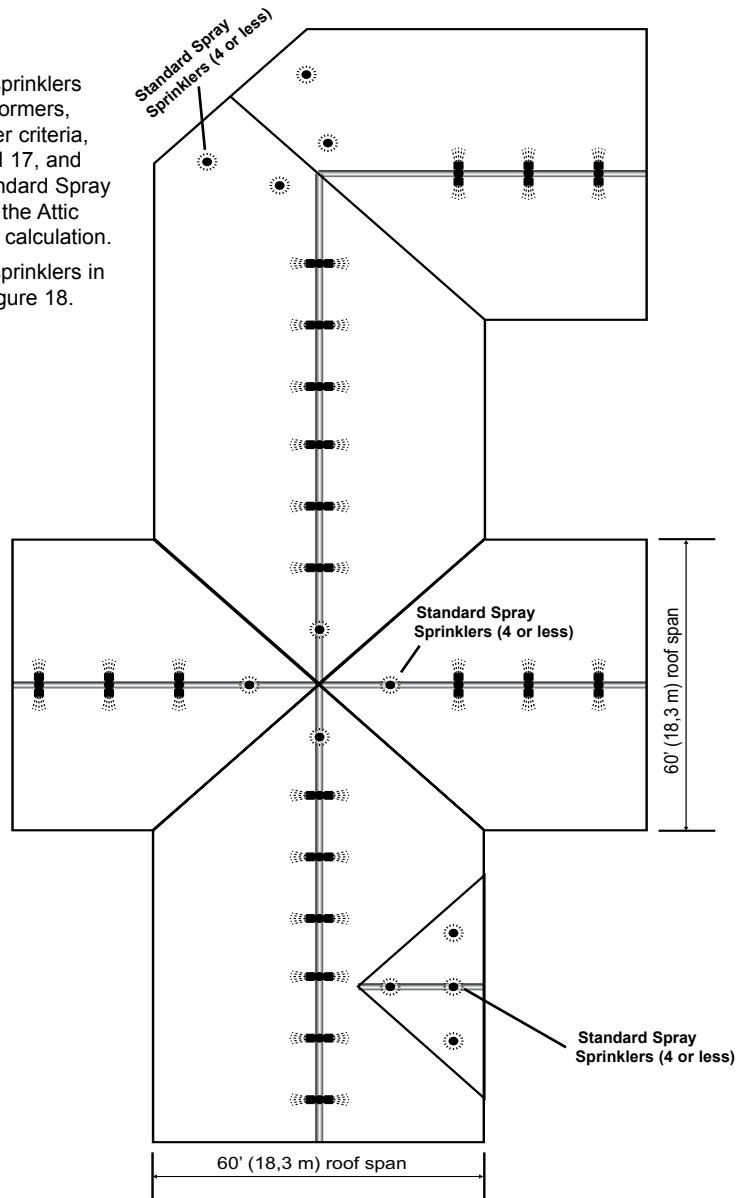

Figure 19:
V-BB Sprinklers and Attic Upright or Standard Spray Sprinklers in a Dormer, at a Hip or at an Ell



TECHNICAL DATA

**MODEL V-BB
SPECIFIC APPLICATION
ATTIC SPRINKLER**

The Viking Corporation, 210 N Industrial Park Drive, Hastings MI 49058
 Telephone: 269-945-9501 Technical Services: 877-384-5464 Fax: 269-818-1680 Email: techsvcs@vikingcorp.com

Calculate the V-BB demand as described in Figures 16 and 17, then calculate the Attic Upright or Standard Spray Sprinklers per NFPA 13. use the most demanding calculation.

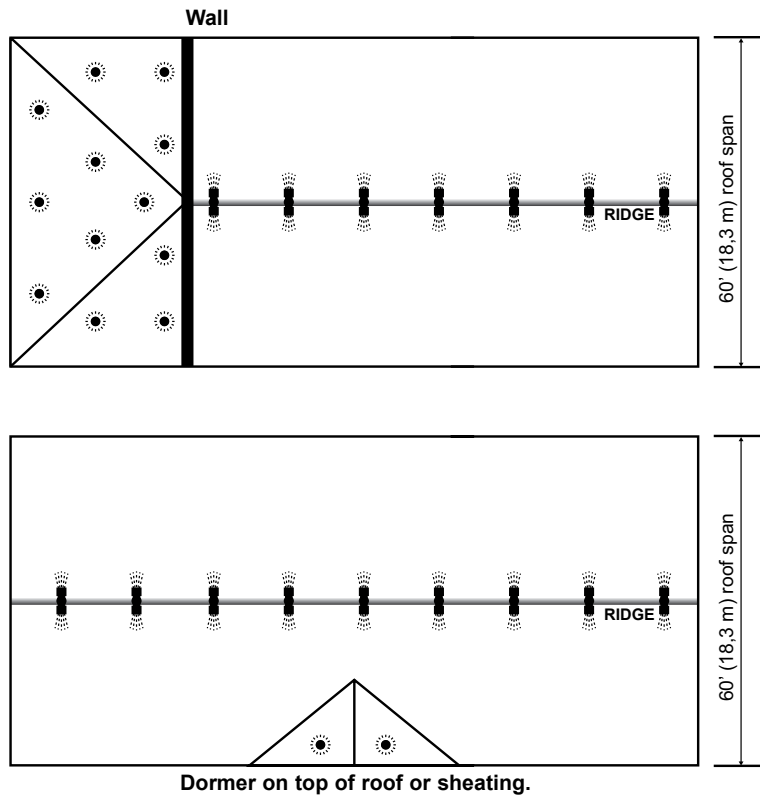

**Figure 20:
V-BB Sprinklers and Attic Upright or Standard Spray Sprinklers Separated by Compartmentalization**